

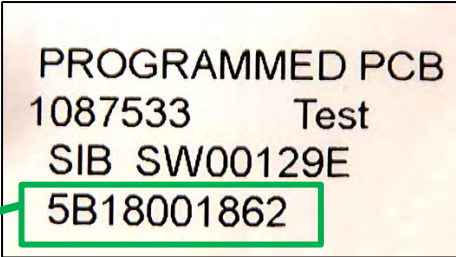

Instruction Sheet

Follow these instructions to replace the SIB (Smart Interface Board).

Subject: 8263468, 8263469, 8263470 SIB (Smart Interface Board) Replacement Instructions
Models affected: Japan LOV, FilterQuick Touch Fryers

McDonald's Japan LOV fryers manufactured prior to 10/31/2017 have SIB boards (1085979), that must be replaced prior to installation. Check the labels below before changing.

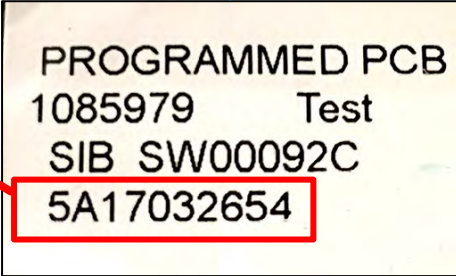
| | | |
|-------------|--|--|
| GOOD | Serial # 5B18004193 or higher |  |
| | SIB boards in this serial range DO NOT need to be replaced. | |
| BAD | Serial # 5A17034182 |  |
| | Serial # 5A17034181 | |
| | SIB boards in this serial range MUST be replaced. | |
| | Serial # 5A13031519 |  |

Ensure the replacement SIB boards are marked with modified Rev A or higher revision (see blue box).

Modified Rev A boards with date code 10/31/17 (see red box) or later have slots that have been notched at the top (see Figure A) and can be used.

Follow the instructions to replace the SIB boards.

Slots notched at the top indicate modified boards.

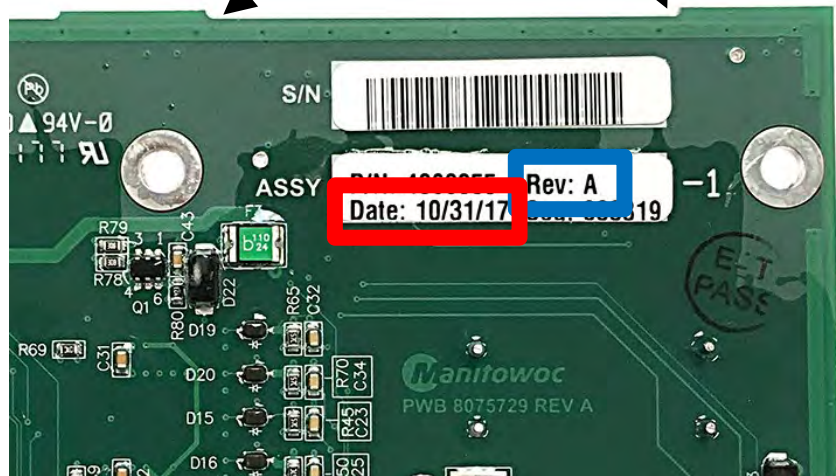

Figure A

1. Disconnect the fryer from the electrical power supply. The fuse located under the bottom of the control box, can be removed, to remove power from individual control boxes (see Figure 1). Turn the fuse cap to remove.
2. If a guard rail is installed, remove the acorn nuts, washer and plates on both ends of the guard (see Figure 2).
3. Slide one end of the guard up the rail at an angle until it can be removed (see Figure 3).
4. Remove the two Phillips head screws from the upper left and right corners of the controller (see Figure 4).
5. Slide the controller up to disengage it from the bezel (see Figure 5).
6. Lift the controller out from the bezel (see Figure 6).

| In This Kit | | |
|------------------------------------|--------------|-----|
| Part # | Description | Qty |
| 1085979, 1087511, or 1087533 | SIB BOARD | 1 |
| 8090349 | SPACER | 3 |
| 8090688 | NUT 4-40 HEX | 3 |
| 8197492 | INSTRUCTIONS | 1 |

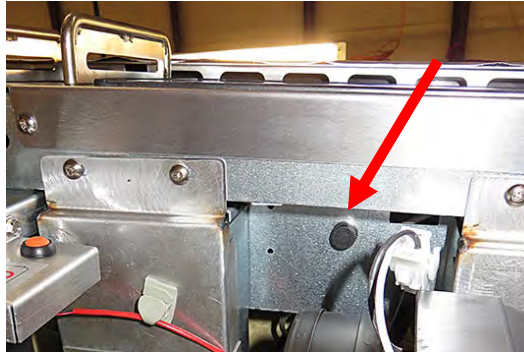

Figure 1

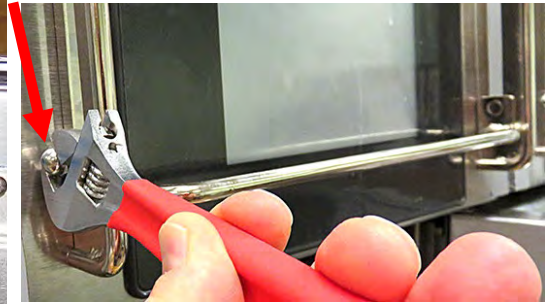

Figure 2



Figure 3

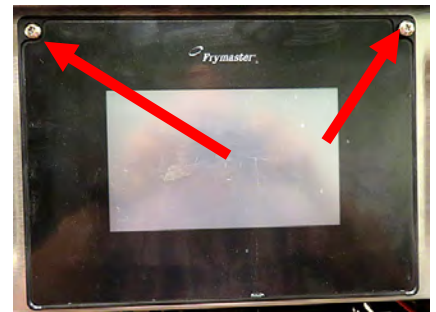

Figure 4



Figure 6



Figure 5

7. Lower the controller and rest it on the bottom of the control box (see Figure 7). The black tether on the right will support the controller.
8. Disconnect the RJ45 cable from the SIB board **FIRST** (see Figures 7 and 8).
9. Disconnect the other cables from the connectors on the back of the controller marking their position for reassembly (see Figure 9).
10. Disconnect the lanyard tether (see Figure 10).
11. Remove the controller and set aside.

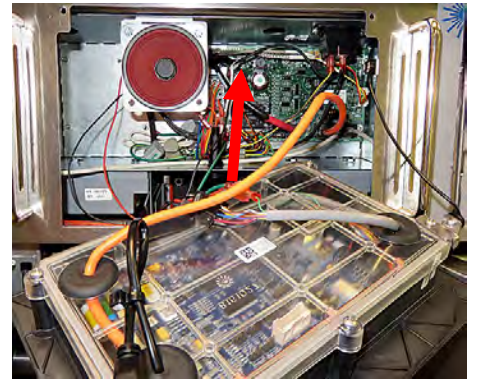

Figure 7

12. Remove the bezel by removing the two 5/16" screws on the bottom of the bezel (see Figure 11) and tilting the bezel up from the bottom and lowering towards the front of the fryer (see Figure 12).

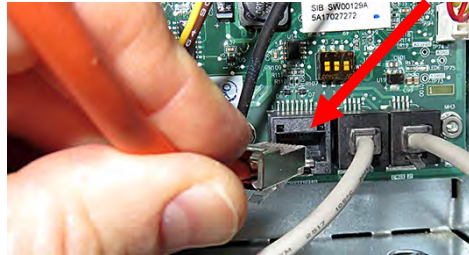

Figure 8



Figure 9

13. Disconnect the cables attached to the SIB board marking or making a note of the connectors to facilitate reconnection (see Figure 13).

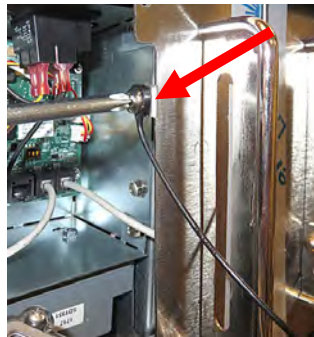

Figure 10

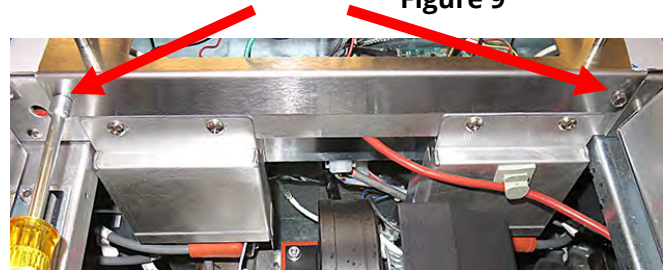

Figure 11

14. Remove the six 1/4" connecting nuts attaching the SIB board (see Figure 14).



Figure 13

15. Remove the SIB board. Use care when removing the board so the spacers that fit over the studs behind the board, are not lost (see Figure 15).



Figure 12

16. Ensure the spacers, behind the board, are in place and install the new board.
17. Reverse previous steps to complete the replacement. When reattaching the controller, place the controller face down, resting on the control box and **reattach the lanyard tether first**. Failure to reinstall lanyard could result in damage to the SIB board.



Figure 14



Figure 15